

- UL 555 & CAN/ULC-S112 Classified Static Fire Damper, 1½ Hr. Label (File # R25565).
- NFPA 80, 90A & 101 compliant.
- NBC and IBC building codes compliant.

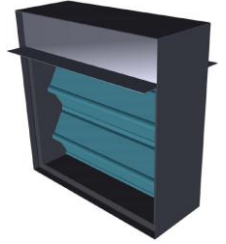

STANDARD CONSTRUCTION

DEPTH: 4 ¼" (108).

FRAME: Roll formed 20 Ga. galvanized steel with hemmed edge.

BLADE: Roll formed 22 Ga. galvanized steel. Interlocking curtain type blade.

FUSIBLE LINK: 165°F (74 C).

OPTIONAL CONSTRUCTION

- Factory supplied Sleeve – 22, 20, 18 or 16 Ga. *Sleeve length required.
- Access Door factory mounted in a common sleeve.
- 212°F (100 C) Fusible Link.
- 1 ½" x 1 ½" Retaining Angles.

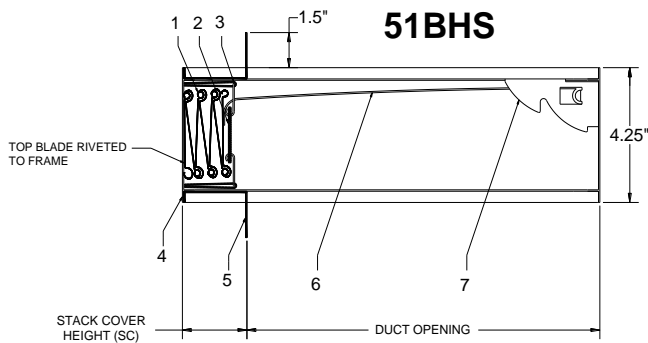
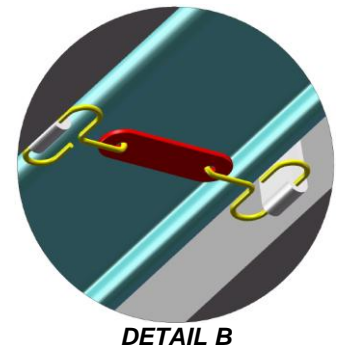
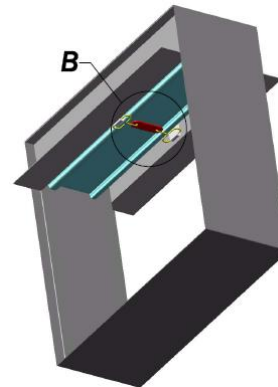
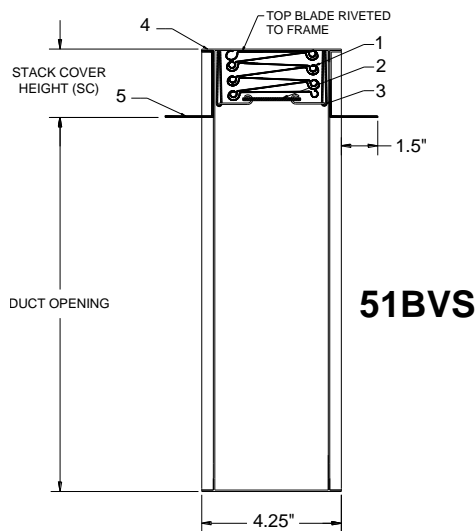

MAINTENANCE RECOMMENDATIONS:

NFPA 80 advises that fire dampers be inspected and tested 1 year after installation, then every 4 years minimum. More frequent inspections may be required due to system use and air conditions, or applicable local codes.

NOTES:

These static dampers are UL/ULC approved for use in HVAC systems where the fans automatically shut down in the event of a fire alarm. 1½ hr. labeled fire dampers are suitable for use in fire separations with a fire resistance rating of 2 hours or less.

Fire dampers must be installed in accordance with manufacturer's instructions. Refer to Alumavent installation instructions for details.

FIRE DAMPER COMPONENTS	
1. Blade	5. Blade Stack Cover
2. Fusible Link Assembly	6. Lock Ramp
3. Link Strap	7. Constant Force Spring
4. Frame	

Dimensions are shown in inches (mm).

B	H
4 (102)	VERT: 5 (127) HOR: 6 (152)
5 (127)	7 (178)
6 (152)	8 (203)
7 (178)	9 (229)
8 (203)	10 (254)
9 (229)	11 (279)
10 (254)	12 (305)
11 (279)	13 (330)
12 (305)	15 (381)
13 (330)	16 (406)
14 (356)	17 (432)
15 (381)	18 (457)
16 (406)	19 (483)
17 (432)	20 (508)
18 (457)	21 (533)
19 (483)	22 (559)
20 (508)	23 (584)
21 (533)	25 (635)
22 (559)	26 (660)
23 (584)	27 (686)
24 (610)	28 (711)
25 (635)	29 (737)
26 (660)	30 (762)
27 (686)	31 (787)
28 (711)	33 (838)
29 (737)	34 (864)
30 (762)	35 (889)
31 (787)	36 (914)
32 (813)	37 (940)
33 (838)	38 (965)
34 (864)	39 (991)
35 (889)	40 (1016)
36 (914)	41 (1041)
37 (940)	43 (1092)
38 (965)	44 (1118)
39 (991)	45 (1143)
40 (1016)	46 (1168)
41 (1041)	47 (1194)
42 (1067)	48 (1219)
43 (1092)	49 (1245)
44 (1118)	51 (1295)
45 (1143)	52 (1321)
46 (1168)	53 (1346)
47 (1194)	54 (1372)
48 (1219)	55 (1397)
49 (1245)	56 (1422)
50 (1270)	57 (1448)
51 (1295)	58 (1473)
52 (1321)	60 (1524)

VERTICAL

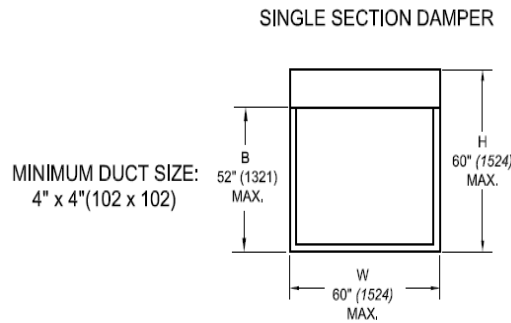

MULTIPLE SECTION DAMPER

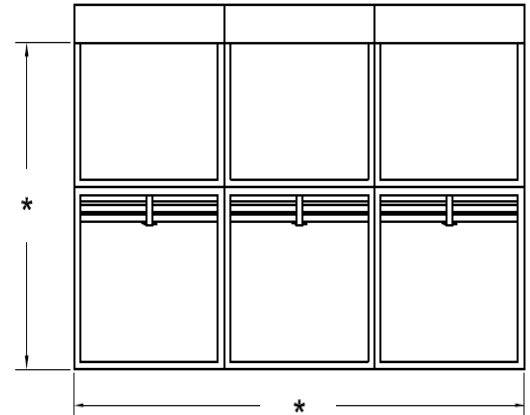

HORIZONTAL

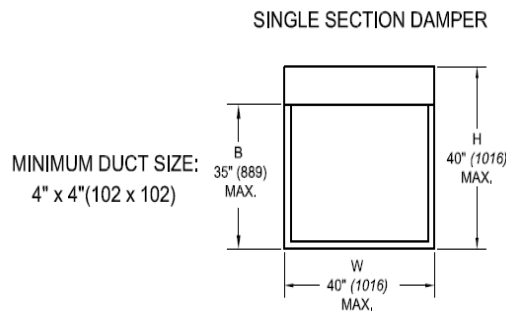

MULTIPLE SECTION DAMPER

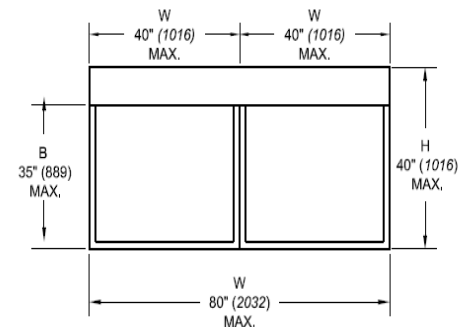

NOTE: CHART IS FOR SINGLE SECTION ONLY. CONTACT FACTORY FOR MULTIPLE SECTION HEIGHTS.

REF. #	QTY.	DUCT WIDTH (W)	DUCT HEIGHT (B)	MOUNT (V/H)	ACCESSORIES

*DAMPER WILL BE MANUFACTURED APPROXIMATELY 1/2" (6) SMALLER THAN GIVEN DIMENSIONS.

PROJECT NAME:		ENGINEER:	
CONTRACTOR:		SUBMITTAL DATE:	

Dimensions are shown in inches (mm).

Information shown herein is subject to change without notice or obligation.

7/2013